

← Glue in place (note locator helpers)  
 ← Gently snap into place (Glue as required)

**Left Gear Shown**  
 Right gear numbers in brackets.

(2) 1

The attachment points on these parts are angled in such a way as to allow them to stay in place to facilitate gluing. Use thin CA, as its viscosity will allow capillary action to form an even and clean bond.

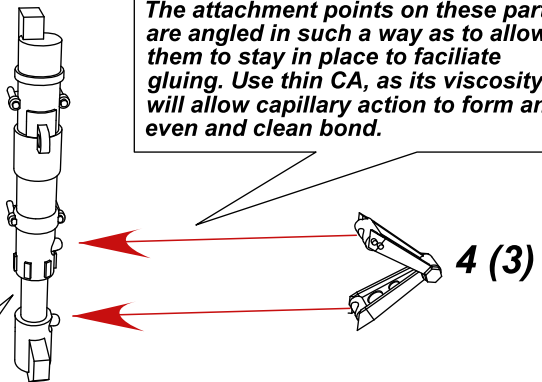

Masking the exposed metal oleo piston is not necessary, since primer/paint/clear layers can be easily scraped off them when complete.

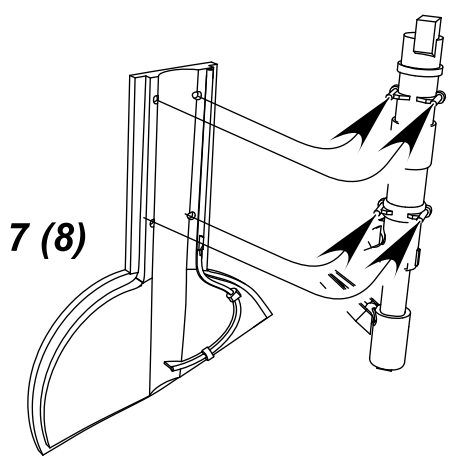

The inner and outer hubs are not interchangeable as far as the tire (9) is concerned. The inner hub is deeper than the outer counterpart. Take this into account when you install the hubs in the tire (9).

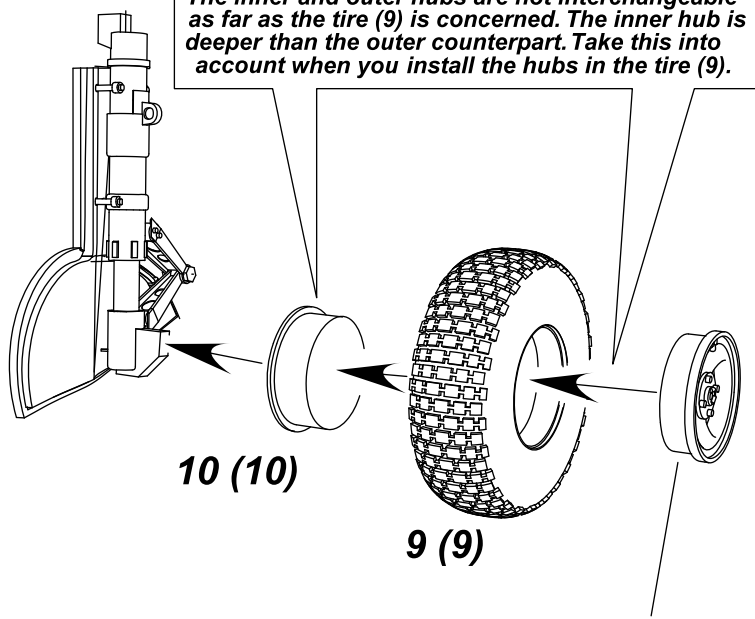

**NOTES:**

- This kit covers later marque Merlin engined Spitfire kits made by Eduard. It includes two different spoke patterns and struts that carried rear facing torque links.
- Aided vision will allow easy lining up of the covers (7 and 8) with the struts (1 and 2 respectively) and the connection is quite sturdy, though this is evident only after the parts are held together.
- Thin CA should be used, and sparingly, the viscosity of which will allow the glue to flow via capillary action, forming a strong and neat bond.
- Part removal from the casting blocks, and any required subsequent clean-up, as always, should be done with a fresh knife blade.