

**Notes:**

Use a new knife blade for cutting and trimming.  
 Our resin is a non-brittle product that is forgiving. Still, care must be exercised to avoid inadvertently slicing through an item such as the brake line or oleo scissor.

There may be some light residual resin on the metal oleo. This is easily removed by gently slicing along the metal, shaving away the residue. The metal is stainless steel and not prone to scuffing.

The gear is very strong, and was thoroughly tested under loaded conditions to ensure its ability to support the model permanently and without creep.

Enjoy our product, and what it can do for your build!

Please, don't hesitate to contact us with any issues, concerns, comments or suggestions.

← Glue in place (note locator helpers)  
 ← Gently snap into place (Glue as required)

**Left Gear Shown**

(Right Gear Components in brackets)

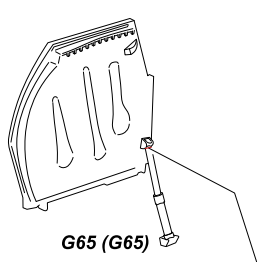
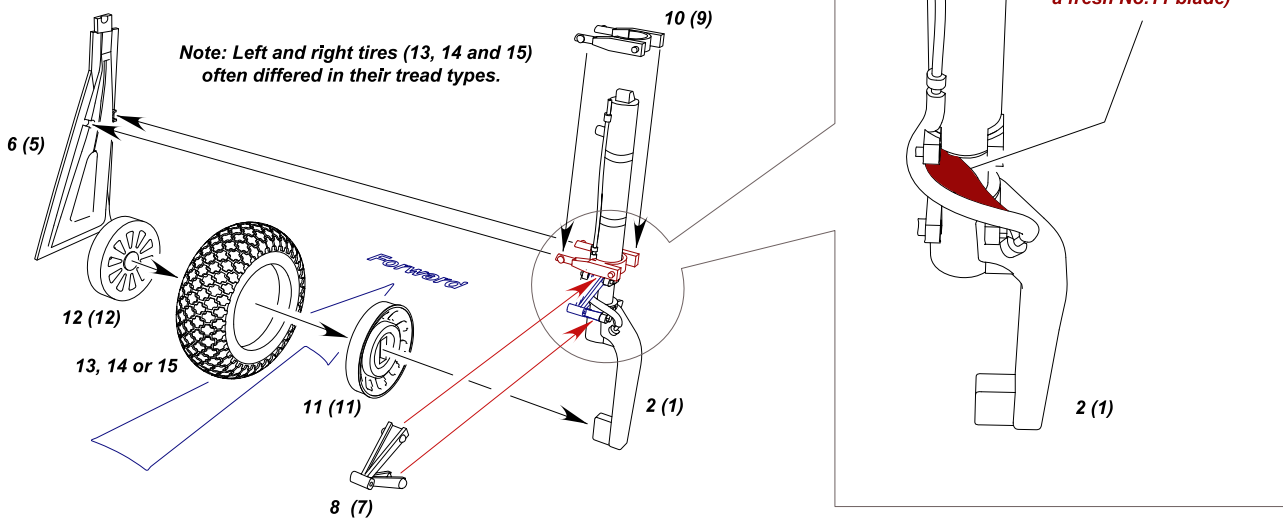

Attach Eduard Part G65 as per their instructions and sever at base. Then, replace the strut with our HybridCAST struts (3 and 4)

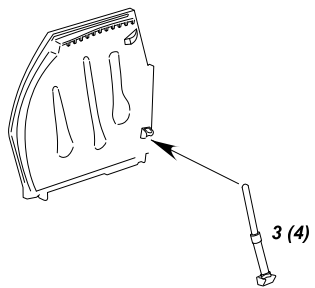

Place the struts with the gear doors (Eduard G31 and G33) secured in place.

(\*) The brake line is a busy (as it should be) but tidy affair. The removal of this film should be contemplated only by those who feel that a significant benefit would be gained. Consider that the line passes through the torque links, and looks very convincing as is.

# PARTS INDEX **20 Parts on 9 Casting Blocks (per a/c)**

Three tread patterns are included to allow various wheel combinations.  
Another three are supplied in KLG4803EDU P-51, Set One

